

# CWL-D-70

# Technical data



- Internal panel in white
- External wall hood in white (RAL 9010) or stainless steel
- Clean, pollen-free fresh air - ventilation with your windows closed, cutting out street noise (not only for those suffering from allergies)
- Removable plastic cross- and countercurrent plate heat exchanger
- Heat recovery of at least 80 %
- Bypass as standard
- Automatic frost protection control
- Low energy consumption due to DC fans
- Electric 275 W preheater coil integrated in the appliance
- Category G4 filter, F7 as optional accessory for supply air
- Fully wired; filter change requirement indicated at appliance
- DIBT approval and passive house certificate applied for

## Technical data

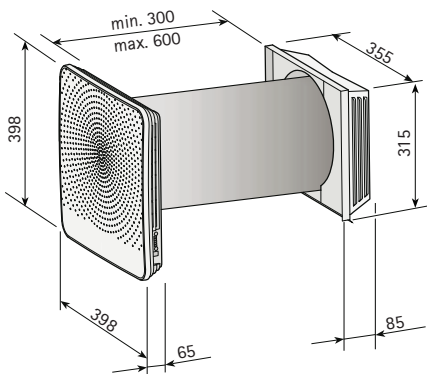

Comfort domestic ventilation system	CWL-D-70
Energy efficiency class	<b>A</b>
Air handling performance at fan stage m <sup>3</sup> /h 1 / 2 / 3 / 4 / 5	15 / 25 / 40 / 55 / 70
Core hole bore mm	Ø260 (with 3° slope towards the outside)
For wall thickness (incl. accessories) mm	500-600 (300-500)
Appliance connection diameter	250
Filter grade	2x G4 (extract air) & 1x G4 (supply air)
Weight kg	12 (13.5 incl. front cover)
Protection IP	Internal unit IP20 / front cover IPX4
Electricity supply	230 V / 50 Hz

## Accessories

- Extension in white (RAL 9010) or stainless steel  
Length: 200 mm for wall thickness 300-400 mm  
Length: 100 mm for wall thickness 400-500 mm
- Additional PCB (for connecting sensors)
- Internal CO2 sensor and humidity sensor
- ON/OFF switch (option)
- G4 and F7 filter sets